

LM1458/LM1558

Dual Operational Amplifier

General Description

The LM1458 and the LM1558 are general purpose dual operational amplifiers. The two amplifiers share a common bias network and power supply leads. Otherwise, their operation is completely independent.

The LM1458 is identical to the LM1558 except that the LM1458 has its specifications guaranteed over the temperature range from 0°C to +70°C instead of -55°C to +125°C.

Features

- No frequency compensation required
- Short-circuit protection
- Wide common-mode and differential voltage ranges
- Low-power consumption
- 8-lead can and 8-lead mini DIP
- No latch up when input common mode range is exceeded

Connection Diagrams

Metal Can Package

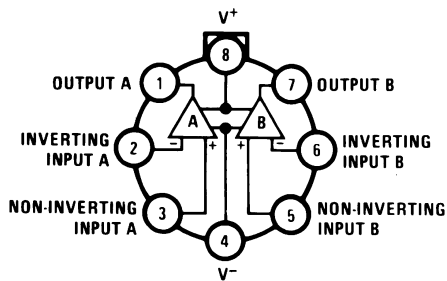

00788602

Top View
Order Number LM1558H,
LM1558H/883 or LM1458H
See NS Package Number H08C

Dual-In-Line Package

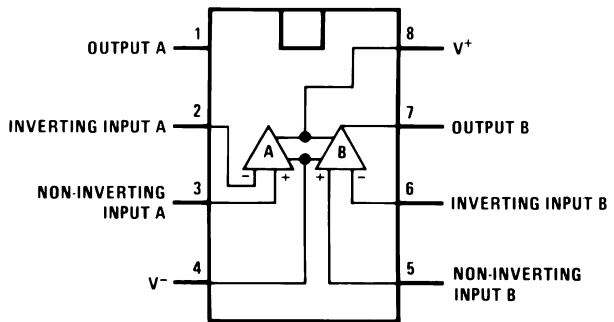

00788603

Top View
Order Number LM1558J/883, LM1458M,
LM1458MX or LM1458N
See NS Package Number J08A, M08A or N08E

Absolute Maximum Ratings (Note 1)

If Military/Aerospace specified devices are required, please contact the National Semiconductor Sales Office/Distributors for availability and specifications.

(Note 5)

Supply Voltage	
LM1558	±22V
LM1458	±18V
Power Dissipation (Note 2)	
LM1558H/LM1458H	500 mW
LM1458N	400 mW
Differential Input Voltage	±30V
Input Voltage (Note 3)	±15V
Output Short-Circuit Duration	Continuous
Operating Temperature Range	
LM1558	-55°C to +125°C
LM1458	0°C to +70°C

Storage Temperature Range	-65°C to +150°C
Lead Temperature (Soldering, 10 sec.)	260°C
Soldering Information	
Dual-In-Line Package	
Soldering (10 seconds)	260°C
Small Outline Package	
Vapor Phase (60 seconds)	215°C
Infrared (15 seconds)	220°C
See AN-450 "Surface Mounting Methods and Their Effect on Product Reliability" for other methods of soldering surface mount devices.	
ESD tolerance (Note 6)	300V

Electrical Characteristics (Note 4)

Parameter	Conditions	LM1558			LM1458			Units
		Min	Typ	Max	Min	Typ	Max	
Input Offset Voltage	$T_A = 25^\circ\text{C}$, $R_S \leq 10\text{ k}\Omega$		1.0	5.0		1.0	6.0	mV
Input Offset Current	$T_A = 25^\circ\text{C}$		80	200		80	200	nA
Input Bias Current	$T_A = 25^\circ\text{C}$		200	500		200	500	nA
Input Resistance	$T_A = 25^\circ\text{C}$	0.3	1.0		0.3	1.0		M Ω
Supply Current Both Amplifiers	$T_A = 25^\circ\text{C}$, $V_S = \pm 15\text{V}$		3.0	5.0		3.0	5.6	mA
Large Signal Voltage Gain	$T_A = 25^\circ\text{C}$, $V_S = \pm 15\text{V}$ $V_{OUT} = \pm 10\text{V}$, $R_L \geq 2\text{ k}\Omega$	50	160		20	160		V/mV
Input Offset Voltage	$R_S \leq 10\text{ k}\Omega$			6.0			7.5	mV
Input Offset Current				500			300	nA
Input Bias Current				1.5			0.8	μA
Large Signal Voltage Gain	$V_S = \pm 15\text{V}$, $V_{OUT} = \pm 10\text{V}$ $R_L \geq \text{k}\Omega$	25			15			V/mV
Output Voltage Swing	$V_S = \pm 15\text{V}$, $R_L = 10\text{ k}\Omega$ $R_L = 2\text{ k}\Omega$	±12	±14		±12	±14		V
		±10	±13		±10	±13		V
Input Voltage Range	$V_S = \pm 15\text{V}$	±12			±12			V
Common Mode Rejection Ratio	$R_S \leq 10\text{ k}\Omega$	70	90		70	90		dB
Supply Voltage Rejection Ratio	$R_S \leq 10\text{ k}\Omega$	77	96		77	96		dB

Note 1: "Absolute Maximum Ratings" indicate limits beyond which damage to the device may occur. Operating Ratings indicate conditions for which the device is functional, but do not guarantee specific performance limits.

Note 2: The maximum junction temperature of the LM1558 is 150°C, while that of the LM1458 is 100°C. For operating at elevated temperatures, devices in the H08 package must be derated based on a thermal resistance of 150°C/W, junction to ambient or 20°C/W, junction to case. For the DIP the device must be derated based on a thermal resistance of 187°C/W, junction to ambient.

Note 3: For supply voltages less than ±15V, the absolute maximum input voltage is equal to the supply voltage.

Note 4: These specifications apply for $V_S = \pm 15\text{V}$ and $-55^\circ\text{C} \leq T_A \leq 125^\circ\text{C}$, unless otherwise specified. With the LM1458, however, all specifications are limited to $0^\circ\text{C} \leq T_A \leq 70^\circ\text{C}$ and $V_S = \pm 15\text{V}$.

Note 5: Refer to RETS 1558V for LM1558J and LM1558H military specifications.

Note 6: Human body model, 1.5 k Ω in series with 100 pF.

Schematic Diagram

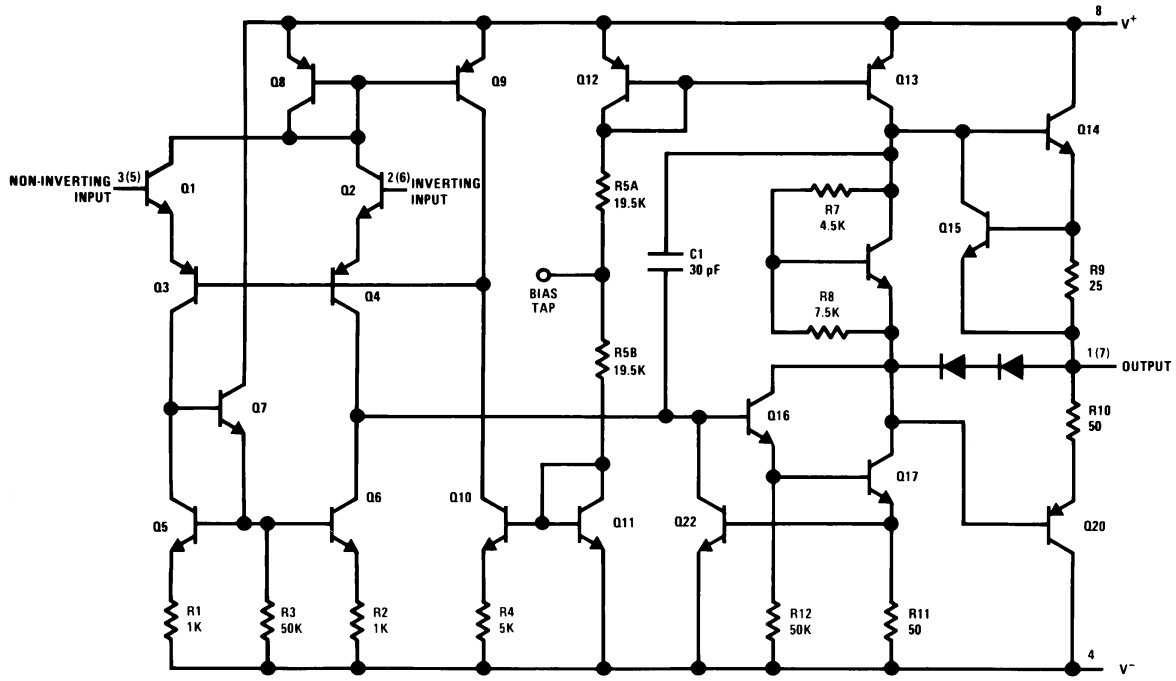

Numbers in parentheses are pin numbers for amplifier B.

00788601

Physical Dimensions inches (millimeters)

unless otherwise noted

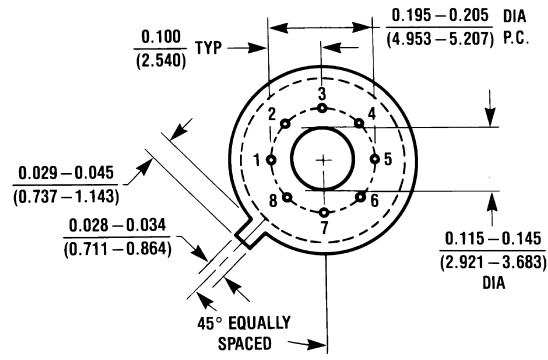
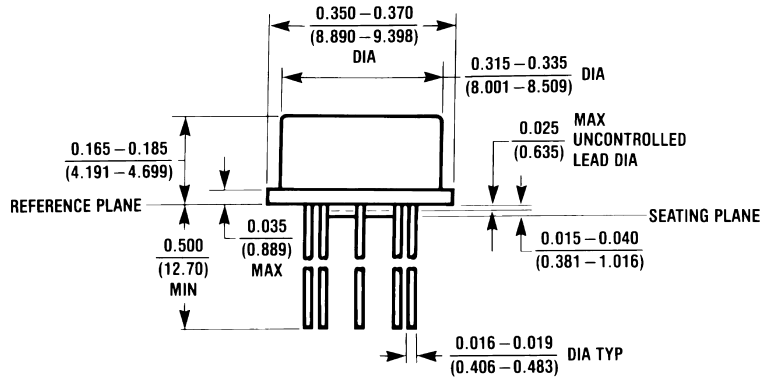

H08C (REV E)

Metal Can Package (H)
Order Number LM1558H, LM1558H/883 or LM1458H
NS Package Number H08C

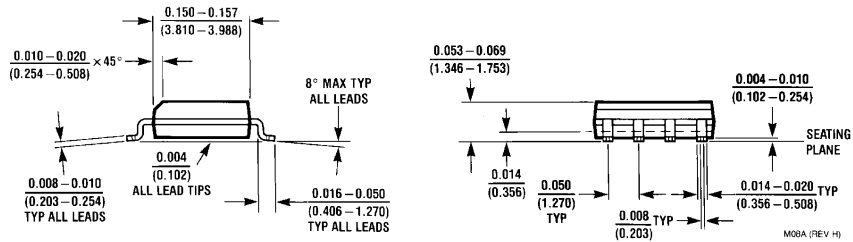
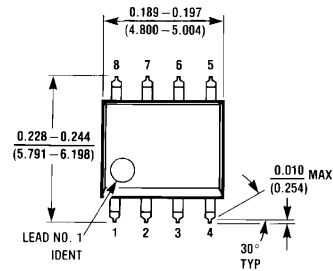

M08A (REV H)

Small Outline Package (M)
Order Number LM1458M or LM1458MX
NS Package Number M08A

Physical Dimensions inches (millimeters) unless otherwise noted (Continued)

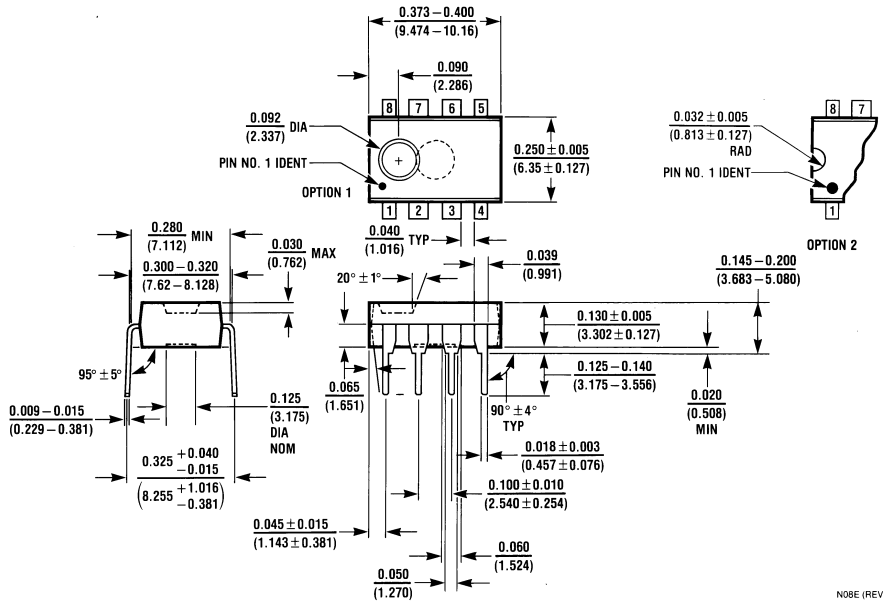

Molded Dual-In-Line Package (N)
Order Number LM1458N
NS Package Number N08E

N08E (REV F)

LIFE SUPPORT POLICY

NATIONAL'S PRODUCTS ARE NOT AUTHORIZED FOR USE AS CRITICAL COMPONENTS IN LIFE SUPPORT DEVICES OR SYSTEMS WITHOUT THE EXPRESS WRITTEN APPROVAL OF THE PRESIDENT AND GENERAL COUNSEL OF NATIONAL SEMICONDUCTOR CORPORATION. As used herein:

1. Life support devices or systems are devices or systems which, (a) are intended for surgical implant into the body, or (b) support or sustain life, and whose failure to perform when properly used in accordance with instructions for use provided in the labeling, can be reasonably expected to result in a significant injury to the user.
2. A critical component is any component of a life support device or system whose failure to perform can be reasonably expected to cause the failure of the life support device or system, or to affect its safety or effectiveness.



National Semiconductor
Americas Customer
Support Center
 Email: new.feedback@nsc.com
 Tel: 1-800-272-9959

National Semiconductor
Europe Customer Support Center
 Fax: +49 (0) 180-530 85 86
 Email: europe.support@nsc.com
 Deutsch Tel: +49 (0) 69 9508 6208
 English Tel: +44 (0) 870 24 0 2171
 Français Tel: +33 (0) 1 41 91 8790

National Semiconductor
Asia Pacific Customer
Support Center
 Email: ap.support@nsc.com

National Semiconductor
Japan Customer Support Center
 Fax: 81-3-5639-7507
 Email: jpn.feedback@nsc.com
 Tel: 81-3-5639-7560

www.national.com